



## Lab 5 Operational Amplifiers

By: Gary A. Ybarra  
Christopher E. Cramer  
Duke University  
Department of Electrical and Computer Engineering  
Durham, NC

### 1. Purpose

The purpose of this lab is to examine the properties of the operational amplifier and learn to design practical op-amp circuits. The concepts and equations of the inverting and non-inverting amplifiers will be verified and the use of the operational amplifier as a comparator will be investigated.

#### 1.1 Equipment

- Agilent 54600B Oscilloscope or Agilent 54622A Deep Memory Oscilloscope (Replacement model: Agilent DSO5012A Oscilloscope or Agilent DSO6012A Oscilloscope)
- Agilent 34401A Digital Multimeter
- Agilent E3631A DC Power Supply
- Agilent E3611A DC Power Supply
- Agilent 33120A Function Generator (Replacement model: Agilent 33220A Function / Arbitrary Waveform Generator)

### 2. Operational Amplifier

An operational amplifier (op-amp) is a device with two inputs and a single output. The output of the amplifier  $v_o$  is given by the formula:

$$v_o = A(v^+ - v^-) \quad (1)$$

Where  $A$  is the open-loop voltage gain of the amplifier,  $v^+$  is the non-inverting input voltage and  $v^-$  is the inverting input voltage. Both  $v^+$  and  $v^-$  are node voltages with respect to ground. Typically, the open-loop voltage gain  $A$  is on the order of  $10^5 - 10^6$ . A resistor is placed between the output node and the inverting input to provide feedback and adjust amplification. When an op-amp circuit behaves linearly, the op-amp adjusts its output current such that the voltage difference between the two inputs is nearly zero.

$$v^- = v^+ \quad (2)$$

Another important feature of the op-amp is that its input resistance is very large and may be taken as infinite in many applications. The most common type of op-amp is the 741 which has an input resistance of 2 M $\Omega$ . This is large enough to be considered infinite in most applications. Because of the high input resistance, only a very small current flows into either input of an op-amp. In practical op-amp circuits, the current flowing into either of the inputs is usually on the order of  $\mu A$ . In the case of an **ideal** op-amp, where the single assumption is made that the open-loop voltage gain  $A$  goes to infinity,

$$i_i = 0 \quad (3)$$

where  $i_i$  is defined to be the current entering the non-inverting input and exiting the inverting input. Equations 2 and 3 can be used to analyze most of the properties of op-amp circuits.



### 3. Op Amp Symbol

Figure 3 shows an operational amplifier with an open-loop voltage gain **A**. The terminals labeled  $+v_{cc}$  and  $-v_{cc}$  are power supply connections to the op-amp and set limits on the voltage which can be produced at the output node. The op-amp we will be using is the 747 as shown in Figure 4. The 747 is a dual op-amp integrated circuit (IC) containing two 741 op-amps.

To use this IC, you must insert it into your board as shown in Figure 1. When properly positioned, the op-amp straddles the gap in the middle of the terminal strip with the 14 pins snugly fit into individual holes in the terminal strip. Observe the notch at one end of the op-amp chip. This notch is used for orientation and identification of the pins. With the notch positioned as shown, pin 1 is always to the left of the notch.

### 4. Op Amp Configuration

As discussed earlier, amplifier circuits that utilize op-amps as linear amplifiers require feedback circuits to control the voltage gain (amplification). The output voltage of the op-amp can never exceed the power

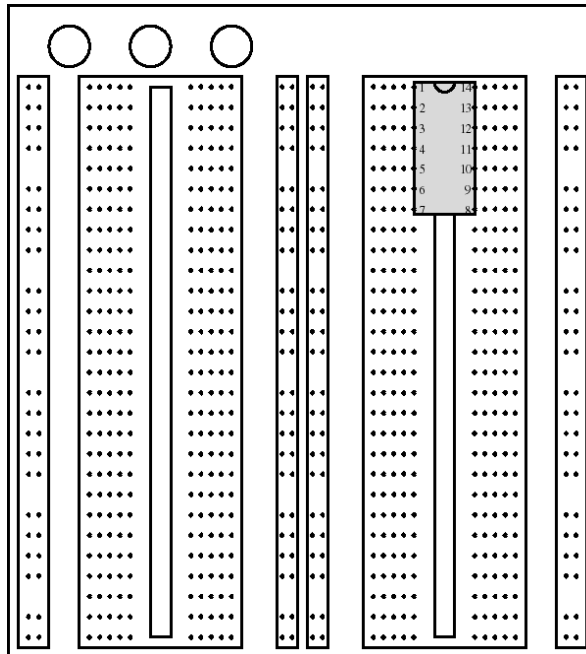

Figure 1: Proto Board with inserted 747.

supply voltage levels, called "the rails" of the power supply. In this section, we shall examine two types of amplifier configurations for the op-amp (Inverting and Non-inverting) and the voltage gain provided by each.



### 4.1 Inverting Amplifier

Figure 5 shows an op-amp in the inverting configuration along with the power supply connections  $+v_{cc}$  and  $-v_{cc}$ . Future circuit diagrams will show only the signal portion of the circuit with the understanding that the power supply connections are required for proper operation of the circuit. To analyze this circuit, we will use Kirchhoff's Current Law (KCL) to determine the output node voltage  $v_o$  and the circuit voltage gain given by the formula

$$\text{voltage gain} = \frac{v_o}{v_s} \tag{4}$$

It is important to distinguish between the voltage gain of the circuit and the open-loop voltage gain of the op-amp. The op-amp is only part of the amplifier circuit. The open-loop voltage gain **A** of the op-amp is the voltage gain from the two op-amp inputs to the op-amp output. While the output node of the whole amplifier circuit may be the output node of the op-amp, the input to the amplifier circuit will not be, in general, a voltage applied across the input terminals of the op-amp.

To analyze an op-amp circuit we first look at the op-amp input nodes (2 and 3). Assuming an ideal op-amp, no current flows into either of the op-amp inputs (Equation 3). The current through  $R_3$  is zero and therefore  $v_3 = 0$ . From Equation 2 we know that  $v_2 = v_3 = 0$ . From this, the current flowing through resistor  $R_1$  is

$$i_{R1} = \frac{v_1 - v_2}{R_1} = \frac{v_s - 0}{R_1} = \frac{v_s}{R_1} \tag{5}$$

From Equation 3 we know that  $i_{R1} = i_{R2} = \frac{v_s}{R_1}$ .

$$i_{R2} = \frac{0 - v_o}{R_2} = i_{R1} = \frac{v_s}{R_1} \tag{6}$$

$$-\frac{v_o}{R_2} = \frac{v_s}{R_1} \tag{7}$$

$$v_o = -v_s \left( \frac{R_2}{R_1} \right) \tag{8}$$



To find the voltage gain (of the amplifier circuit), we need to divide the output voltage by the input voltage:

$$Gain = \frac{v_o}{v_s} = \frac{-v_s \left( \frac{R_2}{R_1} \right)}{v_s} = \frac{R_2}{R_1} \quad (9)$$

Note that the final voltage gain is negative, thus the name *inverting amplifier*. However, sometimes a negative voltage gain is not desired. In such a case, one could either use the output of the inverting amplifier as the input to a second inverting amplifier which would cause the total voltage gain to be positive. However, a simpler method would be to use the non-inverting amplifier configuration.



#### 4.2 Non-inverting Op Amp

The basic configuration for a non-inverting amplifier is shown in Figure 6. The voltage gain for this circuit is  $1 + \frac{R_2}{R_1}$ , it will be left to you as an exercise to verify this voltage gain in your lab report.

### 5. Op Amp as a Comparator

In the previous section, we saw how the use of a feedback resistor can provide stability to an op-amp allowing it to operate as a linear amplifier. In this section, we shall look at an op-amp configuration which does not use feedback: the comparator. The purpose of the comparator is to compare two voltages and produce a signal that indicates which voltage is greater. Figure 7 shows an op-amp as a comparator.

The principle of the comparator is based in Equation 1. Since the voltage gain, **A**, of an op-amp is very large, any difference will be magnified to the power supply rails  $\pm v_{cc}$ , as was discussed in Section 2. If  $v_1$  is greater than  $v_2$  then the difference  $v^+ - v^-$  will be positive and the result will be amplified to  $+v_{cc}$ . If, however,  $v_2$  is greater, then the difference is negative and the result will be amplified to  $-v_{cc}$ . Finally, if the two voltages are *exactly* equal, then the difference will be zero and the output will also be zero.

**Special Note: Whenever you want to remove and op-amp from a breadboard, use the IC EXTRACTOR in the wire jumper box at your lab station.** If you do not use the extractor, you will bend the pins of the chip making it unusable.

### 6. Experimental Procedure

For this portion of the lab exercise, you will be using the springboard and breadboard mounted on the bench at your lab station.

#### 6.1 Power supply

For this experiment, you will need a power supply which can provide +10 volts, -10 volts and a **common** ground. However, the power supply at your station is not equipped to provide both positive and negative 10 volts relative to earth ground. So we are going to "trick" the op-amp circuit by a clever use of a single power supply. Assemble the circuit shown in Figure 8. From the standpoint of the bench (20 V) power supply,  $-v_{cc}$  is ground, **common** is 10 volts and  $+v_{cc}$  is 20 volts. However, from the standpoint of the op-amp, **common** will be used as ground (not the same as earth ground) so that  $+v_{cc}$  is now only 10 volts and  $-v_{cc}$  is -10 volts. We have switched reference frames so that  $+v_{cc}$  is now only 10 volts and  $-v_{cc}$  is -10 volts. Measure and record the values of  $-v_{cc}$  and  $+v_{cc}$  using **common** as the reference (ground) node.

#### 6.2 Inverting Amplifier

- 1) Select, measure, and record the values of three resistors,  $R_1 = 5k\Omega$ ,  $R_2 = 20k\Omega$  and  $R_3 = 5k\Omega$ . Obtain a 747 op-amp. Assemble the circuit shown in Figure 5. Be sure to include the power connections  $+v_{cc}$  and  $-v_{cc}$  from the power supply circuit of Figure 8 to  $+v_{cc}$  and  $-v_{cc}$  of the 747 chip as shown in Figure 4. In addition, the **ground** nodes shown in Figure 5 are to be connected to the common node of Figure 8. Note that Figure 4 shows two  $+v_{cc}$



connections. There are two 741 op-amps in each 747 chip. There is a separate  $+v_{cc}$  for each op-amp. Connect a wire between the two  $+v_{cc}$  pins. Also note that the pins labeled NC are **not connected** to anything.

- 2) Using the function generator apply a 1 volt peak-to-peak, 10 kHz sine wave as  $v_s$ . Note that you need to verify the peak-to-peak voltage using the oscilloscope.
- 3) Using the oscilloscope, display both the op-amp's input and output waveforms. You can do this by using channel 1 at the input and channel 2 for the output. Find the peak-to-peak voltage of the output waveform.
- 4) Record the peak-to-peak voltage of  $v_o$  and find the voltage gain of this op-amp configuration (Equation 4.)
- 5) Increase the peak-to-peak voltage of the function generator until the top of the output sine wave is being cut off. This effect is called clipping, and it occurs when the desired amplification would produce an output voltage greater than the bounds of  $-v_{cc}$  and  $+v_{cc}$  dictated by the power supply. Measure the voltage of the top half of the sine wave and record this value. Do the same thing with the bottom half of the sine wave. How do these values compare to the values recorded for  $+v_{cc}$  and  $-v_{cc}$ ?
- 6) Compare the voltage gain you found in Step 4 to the theoretical voltage gain of the inverting op-amp.

Note: If you find yourself with an op-amp circuit that "won't work" and you have verified that the external wiring is correct, extract the op-amp from the breadboard carefully using the IC EXTRACTOR in the wire jumper box at your lab station, and then use the op-amp tester to determine if your chip is bad.

### 6.3 Non-Inverting Amplifier

- 1) Using the three resistors you acquired for Section 6.2, assemble the circuit shown in Figure 6.
- 2) Using the function generator apply a 1 volt peak-to-peak, 10 kHz sine wave as  $v_s$ . Note that you need to verify the peak-to-peak voltage using the oscilloscope.
- 3) Using the oscilloscope, display the op-amp's output waveform. Find the peak-to-peak voltage of the output waveform.
- 4) Record the peak-to-peak voltage of  $v_o$  and find the voltage gain of this op-amp configuration (Equation 4.)
- 5) Increase the peak-to-peak voltage of the function generator until you achieve clipping. Measure the voltage of the top half of the sine wave and record this value. Do the same thing with the bottom half of the sine wave. How do these values compare to the values recorded for  $+v_{cc}$  and  $-v_{cc}$ ?
- 6) Compare the voltage gain you found in Step 4 to the theoretical voltage gain of the non-inverting op-amp.



### 6.4 Comparator

- 1) You will need two DC power supplies for this portion of the experiment. Get a second DC power supply from the cabinet in the back of the lab if needed.
- 2) Assemble the circuit in Figure 9 using the voltage divider op-amp power supply you used in the previous sections.
- 3) Set voltage supply P1 to 12 volts.
- 4) Measure the voltage at the inverting input of the op-amp. (Note: All voltages in this section should be measured with respect to the negative terminals of the two power supplies.)
- 5) Set voltage supply P2 to 0 volts initially.
- 6) Measure and record the output voltage  $v_o$ .
- 7) While monitoring  $v_o$ , slowly turn the voltage of P2 up until  $v_o$  changes.
- 8) Record the voltage of P2 at the point at which  $v_o$  changes.

### 6.5 Comparator with Triangle Wave Input

- 1) Replace P2 with the function generator set to produce a triangular wave with a frequency of 50 Hz and maximum peak-to-peak voltage.
- 2) Lower the voltage on P1 so that  $+v_{cc}$  and  $-v_{cc}$  are 3.0 and -3.0 volts respectively.
- 3) Use the oscilloscope to view the output voltage (with respect to the node connected to the negative terminals of P1 and P2).
- 4) While reducing the amplitude of the triangle wave, observe the waveform on the oscilloscope.
- 5) Draw the waveform shown on the oscilloscope screen for 3 different triangle wave amplitudes and explain what is happening.

## 7. Project Procedure (To Be Done on Project Board)

Do **NOT** dismantle this circuit when you are through with this exercise. You should keep the entire circuit, including the op-amp IC, on your project board.

For the wireless control system we will be using operational amplifiers in two of the three configurations presented: non-inverting amp and as a comparator. After the signal is received by the receiver, it will be converted from AC to DC (a later experiment). This DC value will be small, under 500 mV, and will need to be amplified in order to be useful. For that purpose, we will use a non-inverting op-amp configuration. The output of the amplifier will then be used as the input to a circuit which will control a servomotor, causing the servomotor to rotate. The servo controller utilizes a comparator.



- 7) Build the power splitter shown in Figure 8 on your project board.
- 8) Select resistors which will provide a voltage gain of 10 for your amplifier
- 9) Measure and record the values of the resistors you have chosen.
- 10) Assemble a non-inverting amplifier circuit as was done in the previous section.
- 11) From the power splitter on your project board, connect  $+v_{cc}$  to +10 volts and  $-v_{cc}$  to -10 volts. Note: since we are amplifying a DC voltage, we will not need more than a -2 to +10 volt power supply, however for simplicity we have constructed the power supply with a -10 to 10 volt range.
- 12) Test the circuit by providing a small voltage to the non-inverting input of the amplifier. Verify that the voltage gain of the amplifier is approximately equal to the theoretical voltage gain.

Analyze this circuit in your lab report to verify that it will amplify a small positive DC voltage by a factor of 10.

PSpice (to be done outside of lab)

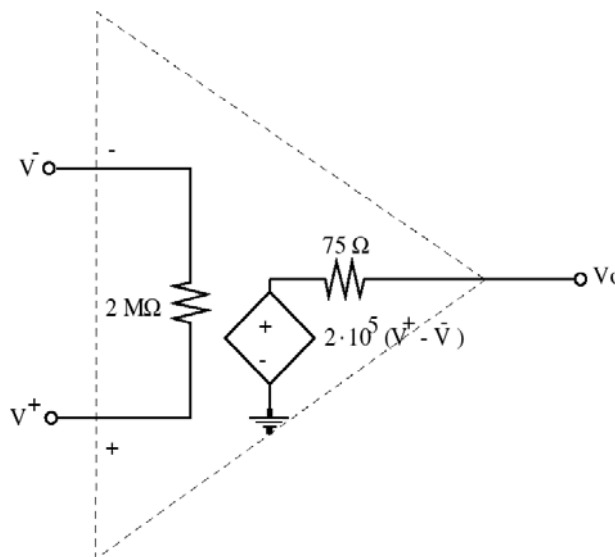

Figure 2: PSpice model for the 741 op-amp

Read Chapter 3 (Section 6 Dependent Sources) in Rashid. In order for you to analyze certain devices such as op-amps and transistors using PSpice, you must use controlled sources. The following controlled sources are available: Voltage Controlled Voltage Source (VCVS), Voltage Controlled Current Source (VCCS), Current Controlled Voltage Source (CCVS) and Current Controlled Current Source (CCCS). These sources are specified in the following manner:





- VCVS: Ename  $n_+$   $n_-$   $n_{c+}$   $n_{c-}$  gain
- VCCS: Gname  $n_{from}$   $n_{to}$   $n_{c+}$   $n_{c-}$  gain  $\left(\frac{1}{\Omega}\right)$
- CCVS: Hname  $n_+$   $n_-$  vname gain( $\Omega$ )
- CCCS: Fname  $n_{from}$   $n_{to}$  vname gain

$n_{c+}$  and  $n_{c-}$  are the nodes of the controlling voltage for voltage controlled sources (either voltage or current sources). vname is the name of the voltage source through which the controlling current flows for current controlled sources (either voltage or current sources). Note that the voltage source through which the controlling current flows can be a dummy (zero voltage) voltage source.

Simulate the circuit you built and tested in Section 6.3 using PSpice and the op-amp model shown in Figure 2. Use a 1 volt peak-to-peak, 10 kHz sine wave as  $v_S$ . Include the PSpice output in your lab report. Compare the theoretical voltage gain, the voltage gain resulting from your PSpice simulation, and the voltage gain measured in lab.

**Note:** The input resistance of the op-amp model of Figure 2 is 2 M $\Omega$ . The PSpice designator for  $10^6$  is **MEG** not **M!** PSpice is not case sensitive and therefore takes M as m which designates  $10^{-3}$  not  $10^6$ .

## 9. Questions

Answer the following questions in your lab report.

1. Verify that the voltage gain of the circuit shown in Figure 6 is  $1 + \frac{R_2}{R_1}$ , using the same general procedures as outlined in Section 4.1. You may assume the op-amp is ideal.
2. We have seen some examples of clipping in an operational amplifier circuit. Explain how and why clipping should be accounted for in designing an amplifier circuit. More specifically, discuss the possible effects of clipping due to poor design in a high-fidelity audio amp.
3. Explain why  $v_o$  turned on when it did in Section 6.4.
4. List several practice uses for a comparator. Hint: Think of contexts in which a physical quantity is compared to a threshold and a decision made based on the comparison. Examples include: fuel level in a gas tank (if below a threshold a dashboard light is illuminated), heart rate monitored in a hospital (if below a threshold a warning tone is produced).

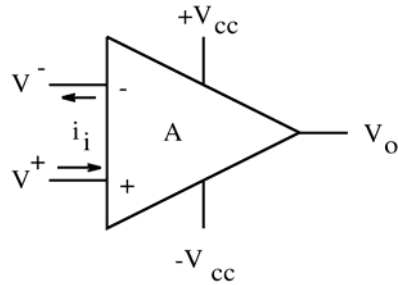

Figure 3: Operational Amplifier

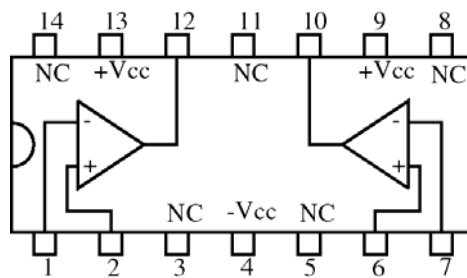

Figure 4: 747 Operational Amplifier

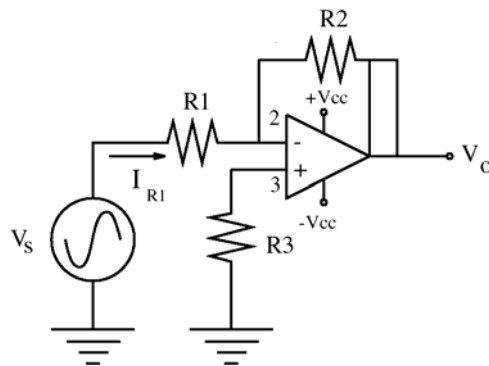

Figure 5: Inverting operational amplifier circuit

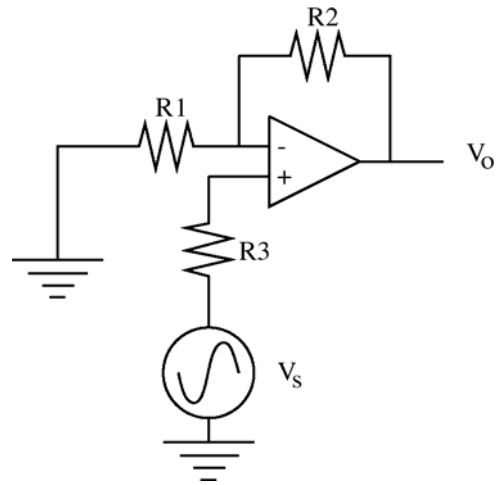

Figure 6: Non-inverting operational amplifier circuit

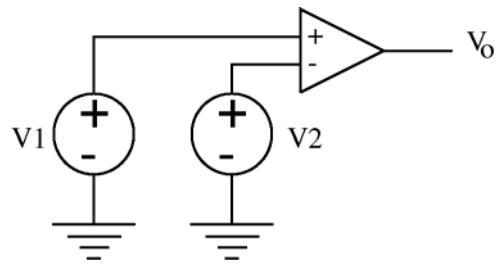

Figure 7: Operational amplifier as a comparator

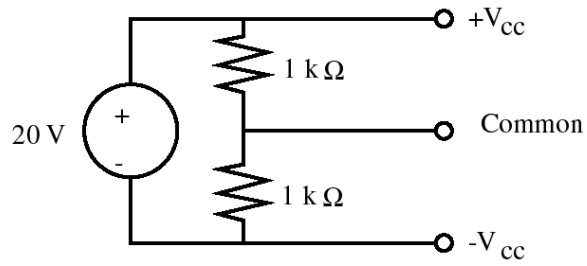

Figure 8: Power supply circuit

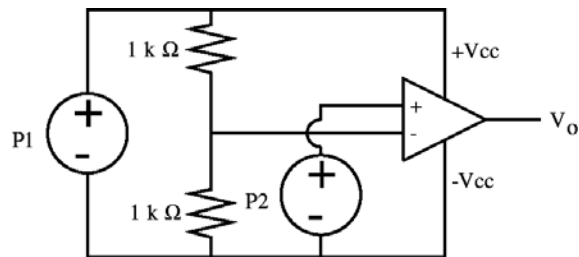

Figure 9: Operational amplifier comparator circuit

These experiments have been submitted by third parties and Agilent has not tested any of the experiments. You will undertake any of the experiments solely at your own risk. Agilent is providing these experiments solely as an informational facility and without review.

AGILENT MAKES NO WARRANTY OF ANY KIND WITH REGARD TO ANY EXPERIMENT. AGILENT SHALL NOT BE LIABLE FOR ANY DIRECT, INDIRECT, GENERAL, INCIDENTAL, SPECIAL OR CONSEQUENTIAL DAMAGES IN CONNECTION WITH THE USE OF ANY OF THE EXPERIMENTS.